

REVISION HISTORY

REV	DESCRIPTION	ZONE

TABLE OF CONTENTS

Sheet 1 Cover Page	Sheet 11
Sheet 2 Block Diagram	Sheet 12
Sheet 3 Project Architecture	Sheet 13
Sheet 4 Load Cell Amp	Sheet 14
Sheet 5 BLE Controller	Sheet 15
Sheet 6 Power and Interface	Sheet 16
Sheet 7 Parts List	Sheet 17
Sheet 8	Sheet 18
Sheet 9	Sheet 19
Sheet 10	Sheet 20

SCHEMATIC NOTES

Unless otherwise specified, components Values are in ohms, μ F, and μ H.

PCBA RENDERS

Replace this with "kibo_image_blender_3d_angled_top" to invoke the Blender 3D Rendering output.

Replace this with "kibo_image_blender_3d_angled_bottom" to invoke the Blender 3D Rendering output.

DESIGN NOTES

DESIGN NOTE:
Example text for informational design notes.

DESIGN NOTE:
Example text for cautionary design notes.

DESIGN NOTE:
Example text for debug notes.

LAYOUT NOTE:
Example text for critical layout guidelines.

DESIGN NOTE:
Example text for critical design notes.

The Git Edit

Drawing Title
Schematic, Assembly Name

Designer JPK	Size A4	Drawing Number S99-9000	Revision NO_TAG+ (Unreleased)
Used On	File Name Test_5.kicad_sch	Release State WORKING	Release Date 2026-03-08
Used On A99-9000	Scale 2:1	KICad E.D.A. 9.0.7	Git Hash 5caa450
			Sheet 1 of 7

	1	2	3	4	5	6
A						
B						
C						
D						
	1	2	3	4	5	6

The Git Edit

Sheet Title				Block Diagram	
Drawing Title					
Schematic, Assembly Name					
Size	Drawing Number			Revision	
A4	S99-9000			NO_TAG+ (Unreleased)	
File Name					
Block_Diagram.kicad_sch					
Release State	WORKING		Release Date		Git Hash
Scale	2:1		KICad E.D.A. 9.0.7		Sheet
					2 of 7

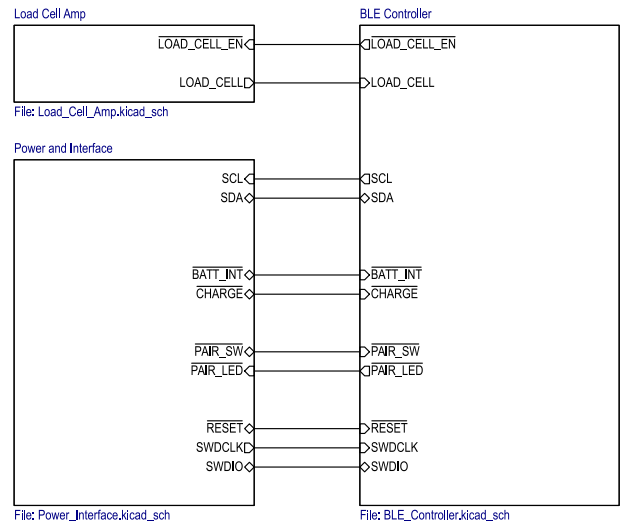

The Git Edit

Sheet Title Project Architecture		
Drawing Title Schematic, Assembly Name		
Size A4	Drawing Number S99-9000	Revision NO_TAG+ (Unreleased)
File Name Architecture.kicad_sch		
Release State WORKING	Release Date	Git Hash 5caa450
Scale 2:1	KICad E.D.A. 9.0.7	Sheet 3 of 7

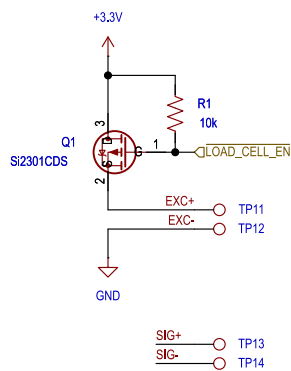

Place four, 1.5mm x 3mm solder pads for Load Cell connections (signals EXC+, EXC-, SIG+, and SIG-). Mark with silkscreen as "E+", "E-", "S+", "S-".

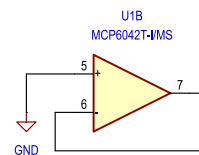
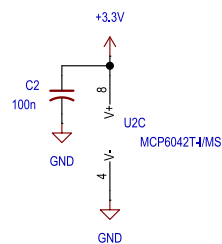
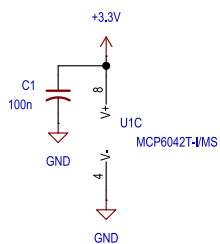
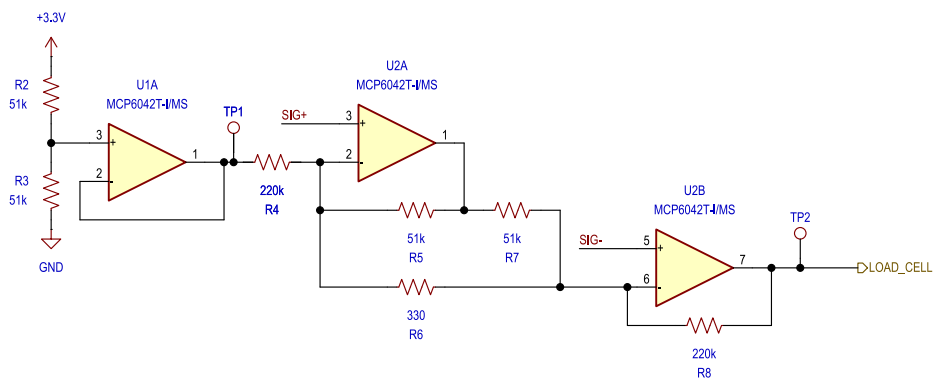

The Git Edit

Sheet Title Load Cell Amp		
Drawing Title Schematic, Assembly Name		
Size A4	Drawing Number S99-9000	Revision NO_TAG+ (Unreleased)
File Name Load_Cell_Amp.kicad_sch		
Release State WORKING	Release Date	Git Hash 5caa450
Scale 2:1	KICad E.D.A. 9.0.7	Sheet 4 of 7

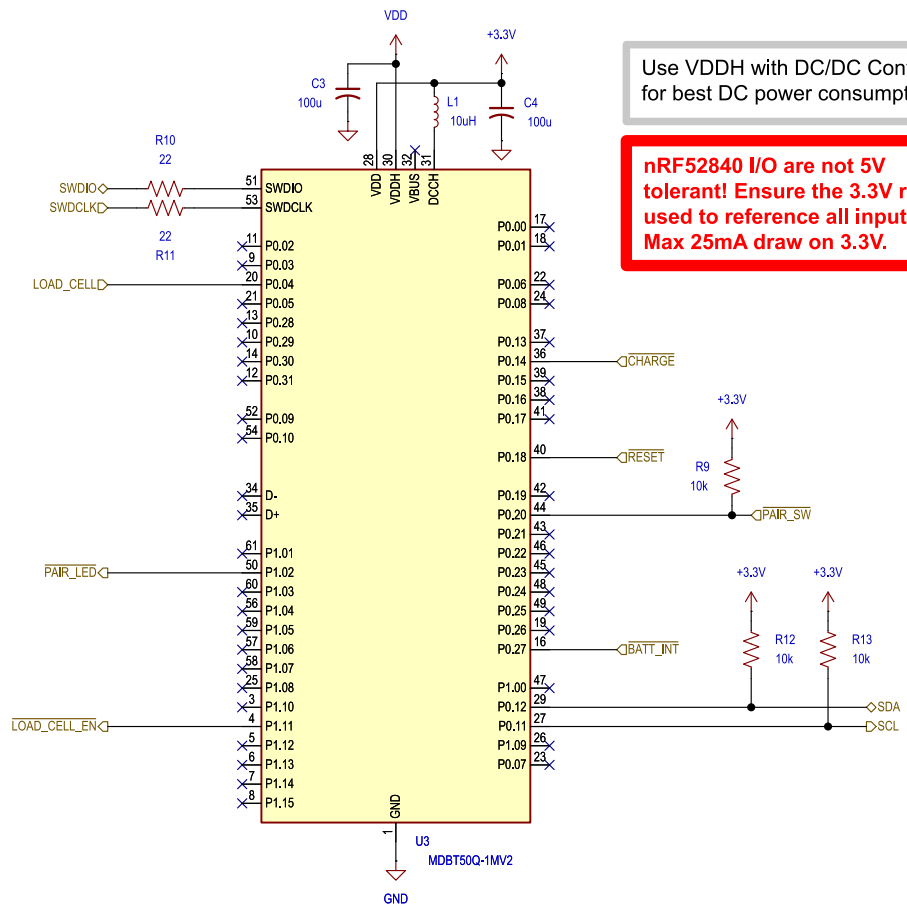

Use VDDH with DC/DC Converter for best DC power consumption.

nRF52840 I/O are not 5V tolerant! Ensure the 3.3V rail is used to reference all inputs. Max 25mA draw on 3.3V.

The Git Edit

Sheet Title Circuit 2		
Drawing Title Schematic, Assembly Name		
Size A4	Drawing Number S99-9000	Revision NO_TAG+ (Unreleased)
File Name BLE_Controller.kicad_sch		
Release State WORKING	Release Date	Git Hash 5caa450
Scale 2:1	KiCad E.D.A. 9.0.7	Sheet 5 of 7

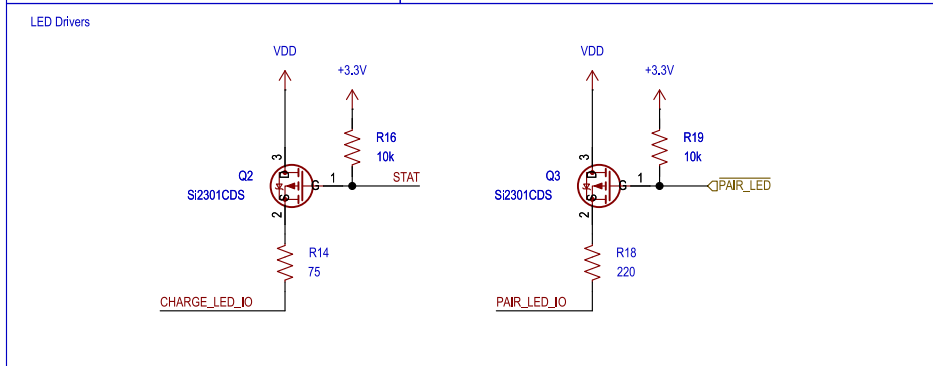
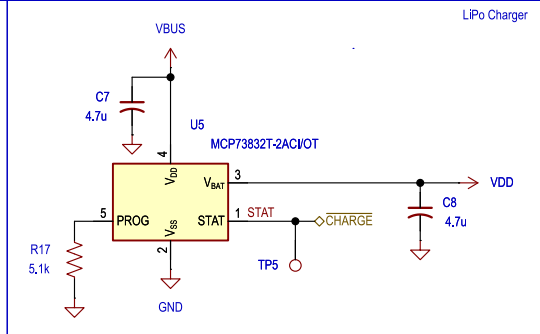
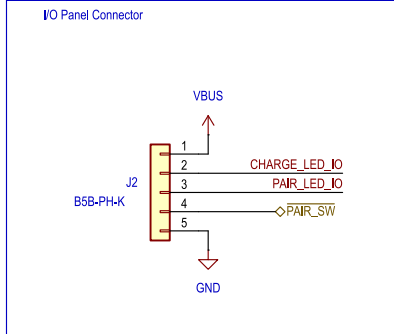
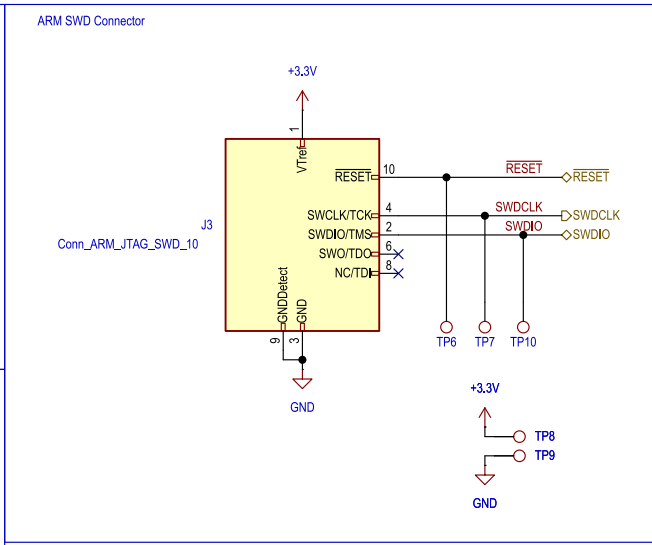
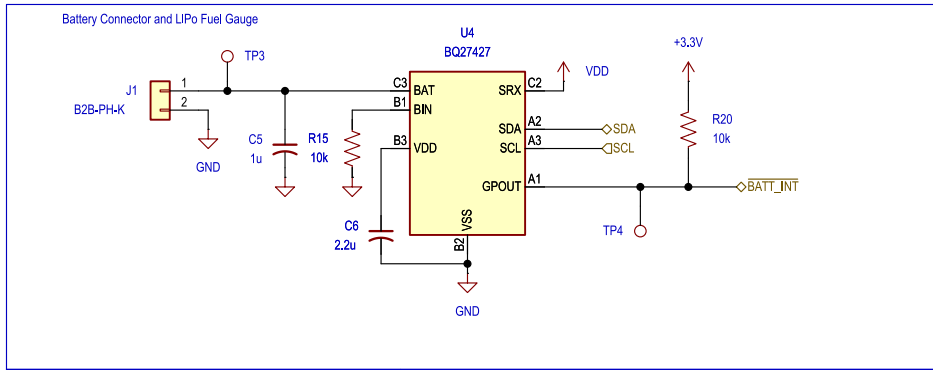

The LEDs on the P25-9010-2 board have the following characteristics:
 - Charge LED: 25mA If, 1.6~2.6V Vf => 75 ohm
 - Pair LED: 5mA If, 2.6~3.1V Vf => 220 ohm

The Git Edit

Sheet Title Battery Interface		
Drawing Title Schematic, Assembly Name		
Size A4	Drawing Number S99-9000	Revision NO_TAG+ (Unreleased)
File Name Power_Interface.kicad_sch		
Release State WORKING	Release Date	Git Hash 5caa450
Scale 2:1	KICad E.D.A. 9.0.7	Sheet 6 of 7

	1	2	3	4	5	6
A						
B						
C						
D						
	1	2	3	4	5	6

The Git Edit

Sheet Title				Parts List	
Drawing Title					
Schematic, Assembly Name					
Size	Drawing Number			Revision	
A4	S99-9000			NO_TAG+ (Unreleased)	
File Name					
Parts_List.kicad_sch					
Release State	WORKING		Release Date		Git Hash
Scale	2:1		KICad E.D.A. 9.0.7		Sheet
					7 of 7